

## POMPĂ CENTRIFUGALĂ CM50 – 250A

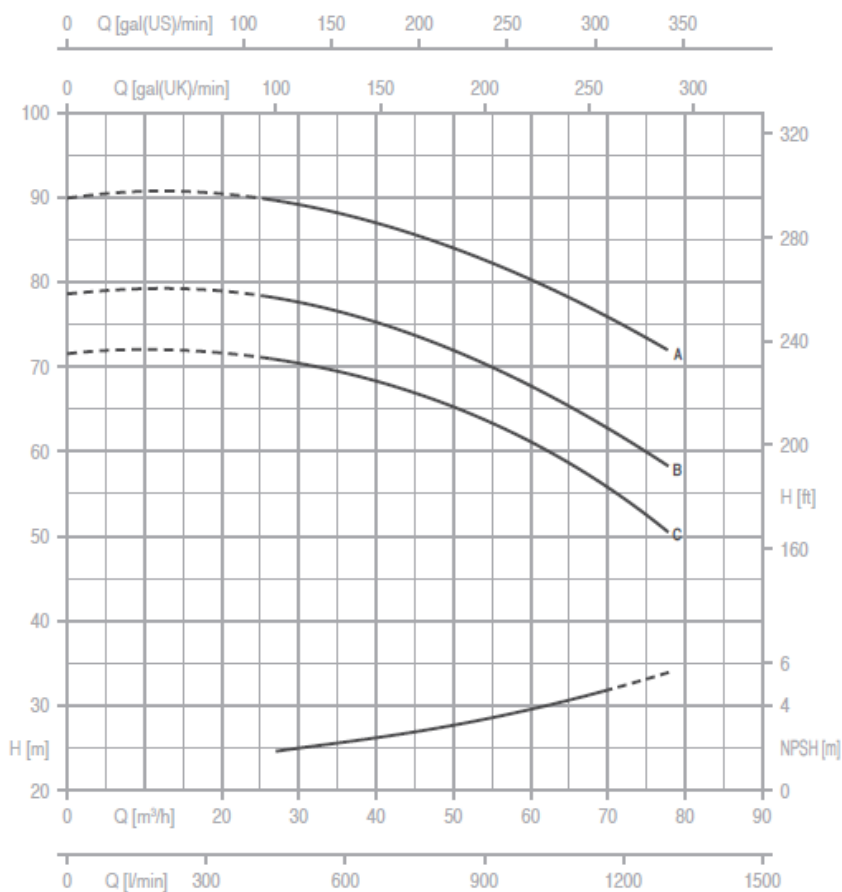

Putere absorbită P1:	28.5 kW
Putere P2:	22.5 kW
Alimentare:	400 V / 50 Hz
Inălțime maximă de refulare:	90 m
Debit maxim:	78000 l/h
Diametru de aspirație:	65 mm
Diametru de refulare:	50 mm



Debit Q (m <sup>3</sup> /h - l/min)												
0	27	30	33	36	39	42	48	54	60	66	72	78
0	450	500	550	600	650	700	800	900	1000	1100	1200	1300
Înălțime de refulare H (m)												
90	89.5	88.8	88.3	87.7	86.9	86.1	84.5	82.7	80.5	78	75.2	71.7

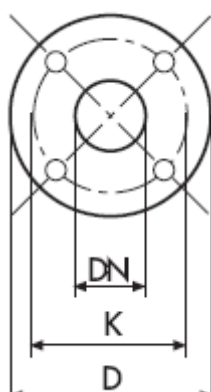

Temperatura maximă a apei:  
 Carcasă pompă:  
 Suport motor:  
 Rotor pompă:  
 Etanșare mecanică:  
 Arbore motor:  
 Clasă de izolație:  
 Clasă de protecție:  
 Flanșe de cuplare pentru aspirație  
 și refulare:

90 °C  
 fontă  
 fontă  
 fontă/bronz/inox  
 ceramică – grafit  
 oțel AISI 316  
 F  
 IP55  
  
 incluse

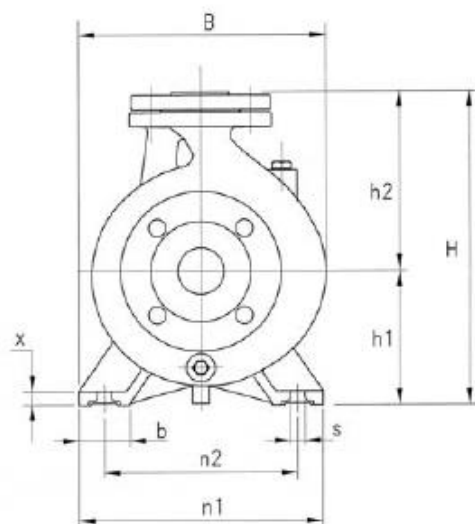
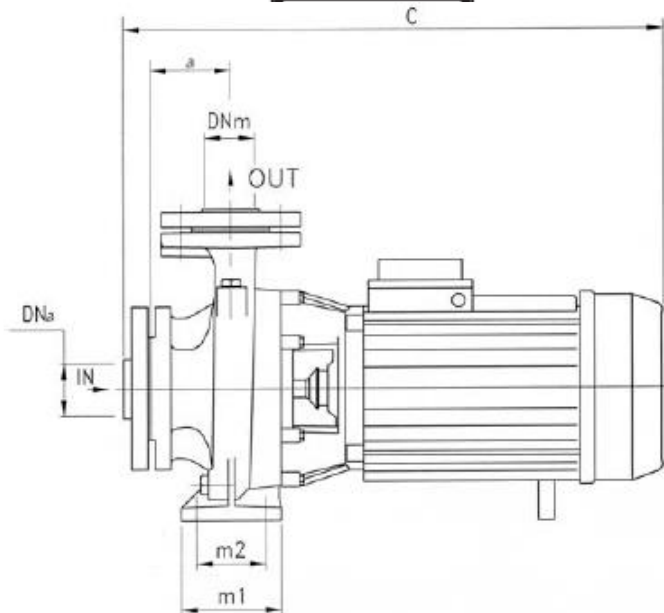

DIMENSIONS (mm)				
DN	D	K	holes	
			n°	ø
32	140	100	4	18
40	150	110	4	18
50	165	125	4	18
65	185	145	4	18
80	200	160	4	18
100	220	180	8	18

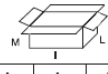

TYPE	DIMENSIONS (mm)																			 Kg
	DNm	DNa	a	h1	h2	m1	m2	n1	n2	b	x	s	C	B	H	I	L	M		
32-160 C	32	50	80	132	160	100	70	240	190	50	12	14	490	240	292	520	260	355	38	
32-160 B	32	50	80	132	160	100	70	240	190	50	12	14	490	240	292	520	260	355	39	
32-160 A	32	50	80	132	160	100	70	240	190	50	12	14	490	240	292	520	260	355	42	
32-200 C	32	50	80	160	180	100	70	240	190	50	12	14	505	268	340	530	305	400	51.5	
32-200 B1	32	50	80	160	180	100	70	240	190	50	12	14	520	268	340	615	310	460	61	
32-200 B	32	50	80	160	180	100	70	240	190	50	12	14	565	268	340	615	310	460	63	
32-200 A1	32	50	80	160	180	100	70	240	190	50	12	14	520	268	340	615	310	460	67	
32-200 A	32	50	80	160	180	100	70	240	190	50	12	14	565	268	340	615	310	460	69	
32-250 C	32	50	100	180	225	125	95	320	250	65	12	14	625	305	405	665	335	535	83	
32-250 B	32	50	100	180	225	125	95	320	250	65	14	14	625	305	405	665	335	535	90	
32-250 A1	32	50	100	180	225	125	95	320	250	65	14	14	625	305	405	665	335	535	95	
32-250 A	32	50	100	180	225	125	95	320	250	65	14	14	695	305	405	735	355	535	120	
40-125 C	40	65	80	112	140	100	70	210	160	50	12	14	495	220	252	520	260	355	36	
40-125 B	40	65	80	112	140	100	70	210	160	50	12	14	495	220	252	520	260	355	37	
40-125 A	40	65	80	112	140	100	70	210	160	50	12	14	495	220	252	520	260	355	40	
40-160 B	40	65	80	132	160	100	70	240	190	50	12	14	500	245	292	520	260	355	47	
40-160 A	40	65	80	132	160	100	70	240	190	50	15	14	500	245	292	520	260	355	50	
40-200 B1	40	65	80	132	160	100	70	240	190	50	15	14	545	273	340	615	310	460	63	
40-200 B	40	65	100	160	180	100	70	265	212	50	15	14	590	273	340	615	310	460	65	
40-200 A1	40	65	80	132	160	100	70	240	190	50	15	14	545	273	340	615	310	460	69	
40-200 A	40	65	100	160	180	100	70	265	212	50	15	14	590	273	340	615	310	460	71	
40-250 C	40	65	100	180	225	125	95	320	250	65	15	14	630	322	405	665	335	535	84	
40-250 B	40	65	100	180	225	125	95	320	250	65	15	14	630	322	405	665	335	535	91	
40-250 A1	40	65	100	180	225	125	95	320	250	65	15	14	630	322	405	665	335	535	96	
40-250 A	40	65	100	180	225	125	95	320	250	65	15	14	700	322	405	735	355	535	121	
50-125 B	50	65	100	132	160	100	70	240	190	50	12	14	525	250	292	520	260	355	47	
50-125 A	50	65	100	132	160	100	70	240	190	50	12	14	525	250	292	520	260	355	50	
50-160 B1	50	65	100	160	180	100	70	265	212	50	12	14	545	270	340	615	310	460	63	
50-160 B	50	65	100	160	180	100	70	265	212	50	12	14	590	270	340	615	310	460	65	
50-160 A1	50	65	100	160	180	100	70	265	212	50	12	14	545	270	340	615	310	460	69	
50-160 A	50	65	100	160	180	100	70	265	212	50	12	14	590	270	340	615	310	460	71	
50-200 C	50	65	100	160	200	100	70	265	212	50	12	14	635	290	360	665	335	535	82	
50-200 B	50	65	100	160	200	100	70	265	212	50	12	14	635	290	360	665	335	535	89	
50-200 A1	50	65	100	160	200	100	70	265	212	50	12	14	635	290	360	665	335	535	94	
50-200 A	50	65	100	160	200	100	70	265	212	50	12	14	705	290	360	735	355	535	122	
50-250 C	50	65	100	180	225	125	95	320	250	65	14	14	705	332	405	735	355	535	125	
50-250 B	50	65	100	180	225	125	95	320	250	65	14	14	750	332	405	815	355	535	140	
50-250 A	50	65	100	180	225	125	95	320	250	65	14	14	750	332	405	815	355	535	149	
65-125 B1	65	80	100	160	180	125	95	280	212	65	14	14	560	280	340	615	310	460	62	
65-125 B	65	80	100	160	180	125	95	280	212	65	14	14	605	280	340	615	310	460	64	
65-125 A1	65	80	100	160	180	125	95	280	212	65	14	14	560	280	340	615	310	460	68	
65-125 A	65	80	100	160	180	125	95	280	212	65	14	14	605	280	340	615	310	460	70	
65-160 C	65	80	100	160	200	125	95	280	212	65	14	14	635	290	360	665	335	535	84	
65-160 B	65	80	100	160	200	125	95	280	212	65	14	14	635	290	360	665	335	535	90	
65-160 A1	65	80	100	160	200	125	95	280	212	65	14	14	635	290	360	665	355	535	95	
65-160 A	65	80	100	160	200	125	95	280	212	65	14	14	705	290	360	735	355	535	120	
65-200 C1	65	80	100	180	225	125	95	320	250	65	14	14	675	330	405	735	355	535	92	
65-200 C	65	80	100	180	225	125	95	320	250	65	14	14	705	330	405	735	355	535	122	
65-200 B	65	80	100	180	225	125	95	320	250	65	14	14	750	330	405	815	355	535	138	
65-200 A	65	80	100	180	225	125	95	320	250	65	14	14	750	330	405	815	355	535	148	
65-250 B	65	80	100	200	250	160	120	360	280	80	16	19	850	370	450	850	380	490	239	
65-250 A	65	80	100	200	250	160	120	360	280	80	16	19	850	370	450	850	380	490	253	
80-160 E	80	100	125	180	225	125	95	320	250	65	14	14	665	330	405	665	335	535	92	
80-160 D	80	100	125	180	225	125	95	320	250	65	14	14	665	330	405	665	335	535	98.5	
80-160 C1	80	100	125	180	225	125	95	320	250	65	14	14	665	330	405	665	335	535	104	
80-160 C	80	100	125	180	225	125	95	320	250	65	14	14	735	330	405	735	355	535	129	
80-160 B	80	100	125	180	225	125	95	320	250	65	14	14	780	330	405	815	355	535	143	
80-160 A	80	100	125	180	225	125	95	320	250	65	14	14	780	330	405	815	355	535	152	
80-200 B	80	100	125	180	250	125	95	345	280	65	16	14	840	355	405	850	380	490	233	
80-200 A	80	100	125	180	250	125	95	345	280	65	16	14	840	355	405	850	380	490	247	